

# Flue Dilution System

A Fan Dilution system is only for use with VLS (very low sulphur) fuel appliances. Each system is designed on the principle of diluting the vented products of combustion sufficiently to reduce the CO<sub>2</sub> content to the required level of below 1% (BS 6644 1991) and less than 100 p.p.m for carbon monoxide.

consequently diluted thus maintaining the low CO<sub>2</sub> and carbon monoxide discharge levels.

The correct formula for fan sizing can be obtained from the Clean Air Act memorandum, BS 6644 or IGE/UP/10 Part1 Edition2 along with certain provisions with regard to the positioning

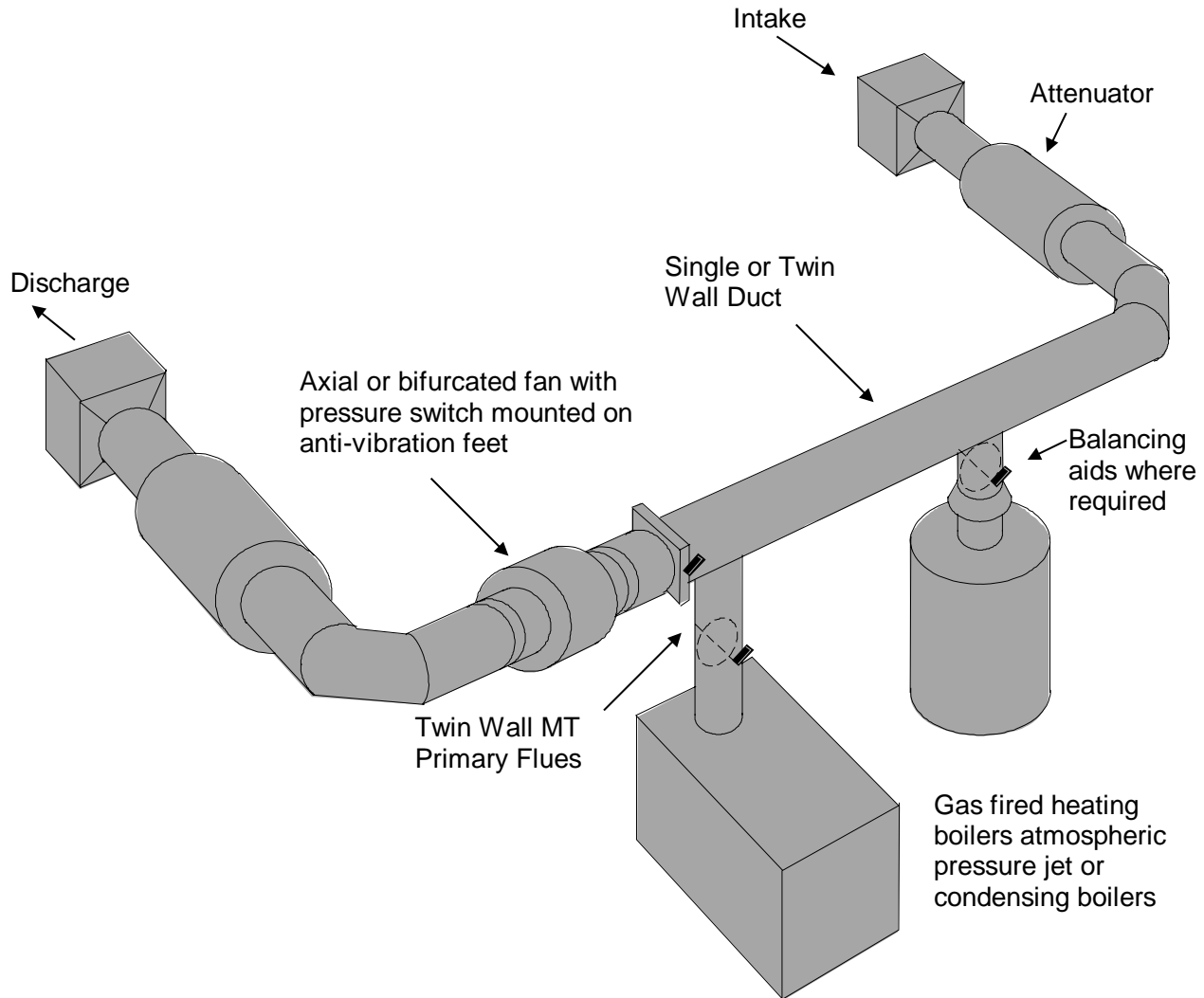

A fan dilution system is normally employed where difficulties are encountered in the provision of a conventional flue or indeed where savings can be made if the only other alternative is a high rise chimney.

The Clean Air Act dictates that this type of system can be fitted to gas fired appliances rated at up to 6 MW, the principle being that fresh air and products of combustion from the boilers are drawn into a duct by a fan and

of the discharge louvre to meet with regulations. Midtherm Engineering have produced an advanced flue sizing programme which incorporates all this information on a data sheet. If you contact our Head Office by telephone (01384) 455811 or fax (01384) 241252, advising us of the plant input rating we can issue this information by return. Our technical department can also advise on all other aspects of fan dilution including the use of condensing boilers and sound attenuation.

---

## Fans

---

It is essential to select the correct type of fan according to the boiler rating and dilution ductwork layout, several types of fan are available these being centrifugal, bifurcated and single or twin external motor driven axial. If a condensing appliance is incorporated in the system the fan case should be epoxy powder coated or of stainless steel construction. A drain point may also be required dependant on the type of fan selected and design of the dilution duct.

---

## Controls

---

The system must incorporate a fan proving safety device normally a pressure differential switch, which interlocks with the boiler control circuit shutting down the appliance if the fan stops operating.

---

## Dilution Ductwork

---

With advances in technology resulting in increased boiler efficiency flue gas temperatures well below acid dew point level are frequently experienced particularly from condensing boilers. Although the sulphur content is low the condensing of the flue gases can lead to the formation of acids. As recognised by IGE/UP/10 Part1. Edition 2 in such circumstances the use of galvanised steel for ducting should be avoided.



Midtherm Engineering always recommend the use of stainless steel in the fabrication of the dilution ductwork and their 4 hour fire rated PS product if condensing boilers are discharging into the dilution duct.

---

## Appliance Types

---

With careful design and the use of balancing aids it is now possible to mix all types of gas fired plant including condensing boilers in a single fan dilution system.

---

## Attenuation

---

Noise breakout from the system should be carefully considered at the design stage particularly for residential applications, attenuators can be incorporated into the flue dilution system if required. It is essential that every system is engineered to comply with Environmental Health noise control requirements.

---

## Louvres

---

The only external indication of a fan dilution system will be the inlet and discharge All Weather Louvres, which can be colour coordinated to suit. In addition to the traditional rectangular and square designs circular, octagonal and triangular louvres can also be provided.

---

## Quality and Standard

---

All Midtherm Engineering products are manufactured in accordance with relevant British Standards and BS EN ISO 9002.

All design and installation work is undertaken by our own team of highly experienced Engineers.

This type of system has been fully tested and approved by British Gas as detailed in their publication Flues for Commercial and Industrial Gas Fired Boilers and Water Heaters.

In addition each system is designed to comply with the requirements of the Clean Air Act memorandum and BS 6644 1991 & IGE.